



Part number

CHP 50 CS229



Brief description:

surface mounting housings with 4 pegs, size "66.40", metal cover, Pg29 x 2, metal version, IP65

Product description		Approvals / Standards	
Version	metal version	Quality mark	 (type:4/4X/12),  , EAC
Series	Surface housings, with 4 pegs	Conformity	CQC, CE
Product type	with 4 pegs and gasket	General ordering information	
Variant	metal cover	EAN13 code	8015747023191
Family	CLASS enclosures	Tariff number	85369095
Size	size "66.40"	Packaging Information	
Technical data		Sub-packaging length	175,00 mm
Operating temperature range (min, max)	-40°C ... +125°C	Sub-packaging height	100,00 mm
Material	metal	Sub-packaging width	235,00 mm
IP degree of protection	IP65	Sub-packaging weight	2,00 kg
Cable entry	Pg29 x 2	Sub-packaging volume	4,11 dm ³
Further technical details		Sub-packaging description	Carton Box
Weight	400,00 g	Sub-packaging quantity	5 Pcs
		Sub-packaging EAN barcode	8015747023207

Part number

CHP 50 CS229



Catalogue drawings

CHP - MHP

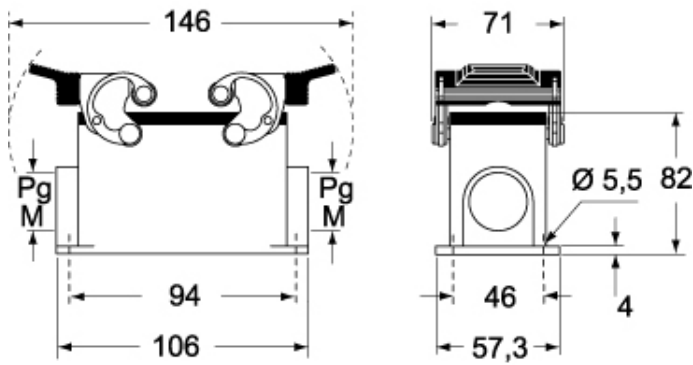

CHP CS - MHP CS

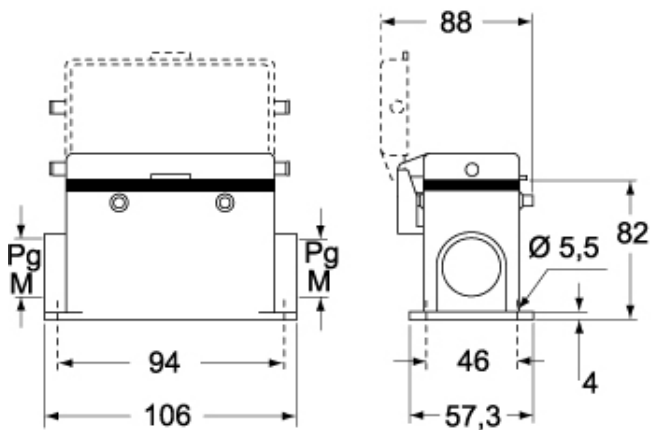

Catalogue drawings

